

EXAM
Database Technology
TDDD12 – TDDD81

June 1, 2017
14.00 – 18.00

Grades

You can get max 30 points. To pass the exam, grade 3, you need 7.5 points in both the practical part (questions 1–3) and the theoretical part (questions 4–8) of the exam. For grade 4 and 5, you need 21 and 27 points, respectively.

Questions

Olaf Hartig will visit the room at 15.00 and at 16.30.

Instructions

- Write clearly.
- Use a separate page for every question.
- Answer in English.
- Give relevant and motivated answers only to the questions asked.
- State the assumptions you make besides those in the questions. None of these additional assumptions should change the spirit of the exercises.

Good luck!

Practical part (15 points)

Question 1. Data modeling with an EER diagram (5 p):

We want to create a database with the following information about concerts and concert-goers.

- A person is identified by a social insurance number (SIN), and has a name and a birth date.
- Some persons are musicians, who may have multiple nicknames and may perform concerts.
- While not every musician performs concerts, those who do, may perform more than one concert. On the other hand, every concert must have one or more musicians performing it.
- Every person may attend concerts (this includes musicians who may attend concerts performed by other musicians). However, not every person has to do so, and there may be concerts that nobody attends. Of course, most concerts are attended by multiple persons.
- For the purpose of our database, each concert has a unique number. Furthermore, concerts have a date, a start time, and an end time.

Please draw an EER diagram that captures the aforementioned information (including cardinality constraints and participation constraints for participation of entities in relationships, as well as totalness constraints and disjointness constraints for specializations). Use the notation as introduced in class. Clearly write down your choices and assumptions in case you find that something in the information above is not clear.

Question 2. EER diagram and relational schema (5 p):

Translate the following EER diagram into an equivalent relational database schema, by using the procedure introduced in class. Your answer should be given in the form of a diagram that shows the relation schemas, including primary keys and foreign keys.

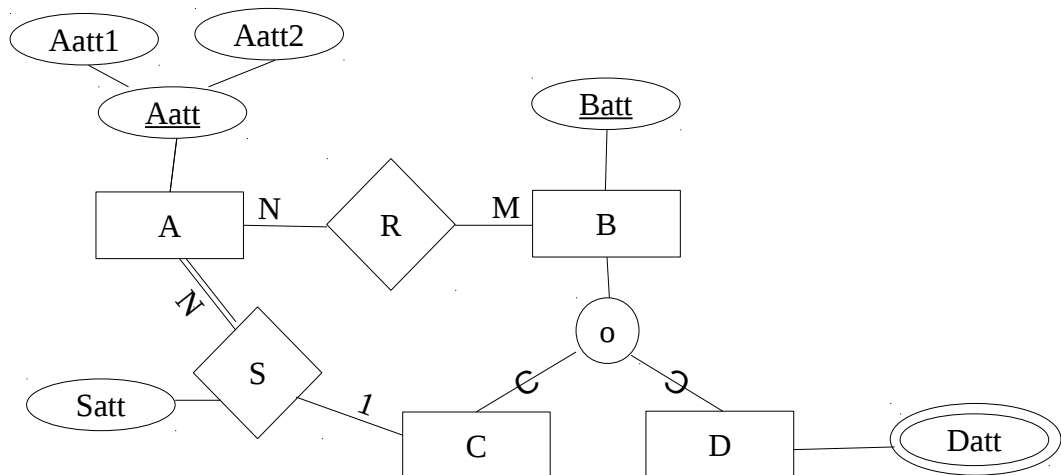

Question 3. SQL (1 + 2 + 2 = 5 p):

Consider the following database schema

Country(*Name*, Code, Capital, Area, Population)

Organization(*Name*, Abbreviation, Established)

IsMember(Organization, Country, Joined)

The attribute *Organization* in the table *IsMember* is a foreign key reference to *Abbreviation* in the table *Organization*. The attribute *Country* in table *IsMember* is a foreign key reference to *Code* in the table *Country*.

Examples of the tuples for the above relational schema are as follows:

Country(Sweden, SWE, Stockholm, 449964, 9514000)
Organization(European Union, EU, 1952)
IsMember(EU, SWE, 1995-01-01)

Provide SQL queries to answer the following questions.

- (a) List the country names of all the European Union (Abbreviation: 'EU') members.
- (b) List the names of all organizations that do *not* have any members.
- (c) List the name of every country that is the member of at least five organizations.

Theoretical part (15 points)

Question 4. Normalization (1 + 3 = 4p):

Consider a relation schema $R(A, B, C, D)$ for which the following functional dependencies exist:

FD1: $\{A\} \rightarrow \{C\}$
FD2: $\{B\} \rightarrow \{D\}$
FD3: $\{C\} \rightarrow \{A\}$
FD4: $\{D\} \rightarrow \{B\}$

- (a) Assume a relation state of R that contains the tuples (a1,b2,c6,d1) and (a2,b2,c6,d4). Is such a state a valid state of R (taking into account the FDs)? Explain your answer briefly (just writing “yes” or “no” without any further explanation does not earn you any points).
- (b) Normalize R up to Boyce-Codd normal form (BCNF). Explain your solution step by step. Bear in mind that a relation may have several candidate keys.

Question 5. Data structures (1 + 1 + 1 = 3 p):

Assume we have a sorted file with 1,000,000 records, a block size of 40,000 bytes, and unspanned allocation. Each record has a size of 40 bytes. The records have two fields, X and Y, where X is a key field (and Y is not). The file is sorted on Y.

- (a) Calculate the blocking factor of the file and the overall number of blocks that the file has.
- (b) Calculate the average number of block accesses needed to find a record **i**) with a given value for Y, and **ii**) with a given value for X (do not assume the existence of any index).
- (c) To speed up the retrieval we may use an index. Assume we want to speed up finding a record with a given value for X. Name **i**) the type of *single-level* index that we can use in this case and **ii**) the concrete number of index records that this index would have for our file.

Recall that $\log_2(2^x) = x$. That is, $\log_2(1) = 0$, $\log_2(2) = 1$, $\log_2(4) = 2$, $\log_2(8) = 3$, $\log_2(16) = 4$, $\log_2(32) = 5$, $\log_2(64) = 6$, $\log_2(128) = 7$, $\log_2(256) = 8$, $\log_2(512) = 9$, $\log_2(1024) = 10$, $\log_2(2048) = 11$, $\log_2(4096) = 12$, $\log_2(8192) = 13$, $\log_2(16384) = 14$, etc.

Question 6. Transactions and concurrency control (1 + 1 + 1 = 3 p):

The following three tasks (a–c) are independent of one another. That is, the pairs of operations in (a) have nothing to do with the schedule in (b), which in turn does not need to be considered when answering (c).

(a) For each of the following four pairs of operations, indicate whether the pair conflicts. (Points will be deducted for wrong answers!)

pair 1: $r_2(X), w_2(X)$

pair 2: $w_4(Y), w_2(Y)$

pair 3: $r_3(Z), w_2(Z)$

pair 4: $w_3(Z), w_2(X)$

(b) Consider the following schedule. Is it serializable? Justify your claim.

Step	T1	T2	T3
1	read(x)		
2	$x=x+1$		
3	write(x)		
4		read(x)	
5		$x=x+1$	
6		write(x)	
7		read(z)	
8		$z=z+1$	
9		write(z)	
10			read(z)
11			$z=z+1$
12			write(z)
13			read(y)
14			$y=y+1$
15			write(y)
16	read(y)		
17	$y=y+1$		
18	write(y)		

(c) Specify the two-phase locking (2PL) protocol; i.e., what does a transaction have to do to follow the protocol?

Question 7. Database recovery (1 + 1 + 2 = 4 p):

- (a) List the steps that a DBMS performs to create a checkpoint of a database.
- (b) Assume a DBMS applies the deferred update strategy without using checkpointing. Then,
- i) when does the DBMS write out to disk the data blocks that a transaction has updated, and
 - ii) when does the DBMS write out the log buffers that contain log records about the transaction?
- (c) Given the following log, apply each of the two recovery algorithms for the two immediate update strategies described in the course. In each of the two cases, list the operations that are performed during recovery in the order in which they are performed.

Start-transaction T2
Write-item T2, B, 3, 4
Start-transaction T3
Write-item T3, A, 7, 8
Checkpoint
Write-item T3, A, 8, 1
Commit T2
Checkpoint
Write-item T3, A, 1, 5
Start-transaction T4
Write-item T4, B, 4, 5
Write-item T4, B, 5, 10
Commit T3
Checkpoint
Start-transaction T1
Write-item T1, C, 8, 9
Commit T4
* system crash *

Question 8. Query Processing (1 p):

- (a) Assume two relations, R and S . Let pr and ps be the number of disk pages occupied by the file for relation R and for S , respectively. What is the I/O cost (in terms of page reads) of using the nested loop join algorithm (NLJ) to join R and S if the outer loop of the NLJ iterates over R ?