

Exam questions for Linear Control System Design, SSY285

January 9th, 2017

Cover page

1. Timeframe: 4 hours.
2. Examiner: Balazs Kulcsar, internal phone number: 1785, kulcsar@chalmers.se
3. Necessary condition to obtain the exam grade is to have the course's mandatory project (all assignments and the lab) approved. Without approved mandatory project, the archived exam results are invalid.
4. 20 points can be reached in total (with 0.5 point resolution), Lic/PhD students have to reach at least 12 points to pass. For Msc students Table 1 shows the grading system.

Table 1: Grading for Msc students

Points	Grade
10 ... 11.5	3
12 ... 15.5	4
16 ... 20	5

5. During this written exam, it is *optionally* permitted to use printed materials such as:
 - *Either* of the course textbooks (only 1 book): (hardcopy or plain printed version, without notes inside!)
 - (i) *Feedback systems, an introduction for scientists and engineers* by K. J. Åström and R. M. Murray, ISBN-13: 978-0-691-13576-2, OR
 - (ii) *Reglerteknikens grunder* by Bengt Lennartson, ISBN: 91-44-02416-9, (iii) *Reglerteknik : grundläggande teori*, T Glad, L Ljung.
 - 1 piece of A4 paper, with *hand written* notes on both sides. Copied sheet can not be used.
 - Pocket calculator (non-programmable, cleared memory, without graphical plotting function).
 - Mathematical handbook Beta (without notes inside!).
6. Note that phones, tablets, computers, any other communication devices are not allowed to use during the exam session. In scheduled exam session for the course at Chalmers, teacher(s) will show up in person in the first and last 60 min.
7. Examination results will be advertised no later than January 20th 2017 (pingpong.chalmers.se). Inspection of results in person, January 23th 10-11 am, E-building floor 6, room 6414 (S2 Bla Rummet).

If you reach 18 or more points contact me for collecting your ☺ ! Good luck!

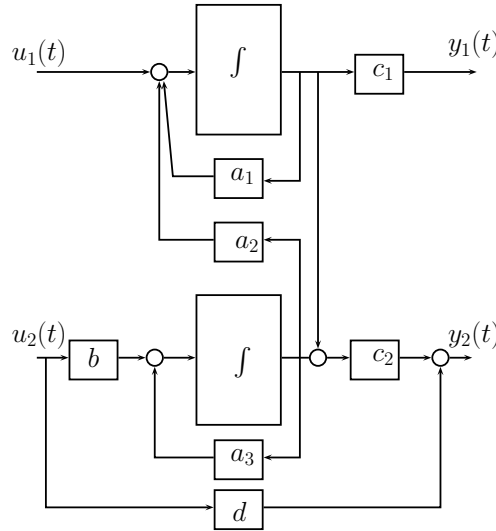

Figure 1: Open-loop block diagram

Questions

- Briefly answer and motivate the following questions (each **0.5 point**, total **2 point**).
 - What is the state-transition matrix and what is the state-transformation matrix?
 - Briefly explain the concept behind the principle of separation.
 - What is the main methodological difference (feedback design) between LQR and LQG?
 - How does the multiplicative robust stability test relate to the Small Gain Theorem?
- Given the following system model by means of block diagram in Figure 1 with $a_1 = -1, a_2 = 0.6, a_3 = -1.5, b = 4, c_1 = 0.5, c_2 = 2, d = 1$.
 - Derive the state-space representation in terms of matrix differential equation (A, B, C, D) for the depicted in Fig. 1 with the constants given (**1 point**).
 - By using the matrices (A, B, C, D) , compute the transfer function matrix $G(s)$ (**2 point**).
 - Based on $G(s)$, is this a non-minimum phase representation? Is the transfer function matrix strictly proper? Is the system input-output stable? Is the system internally stable? Briefly motivate your answers (**2 point**)!
 - Cross channel steady state gains. What is the steady state value for y_1 if $\forall t, u_1 = 0, u_2 = 1$ is applied? What is the steady state value for y_2 if $\forall t, u_1 = 1, u_2 = 0$ is applied? (**1 point**)!
- Given the following state-space representation by,

$$x(k+1) = \begin{bmatrix} -1.5 & -0.5 \\ -\alpha & 0 \end{bmatrix} x(k) + \begin{bmatrix} \frac{1}{\alpha} \\ 2 \end{bmatrix} u(k)$$

$$y(k) = \begin{bmatrix} 2 & \frac{1}{\alpha} \end{bmatrix} x(k)$$

with $|\alpha| < \infty$,

- Is the state-space representation minimal for all α ? (**1 point**)
- With $\alpha = -1$ is the representation controllable? (**1 point**)
- With $\alpha = 1$, find the reachable (similarity) state transformation matrix T . With the help of T transform the system into a reachable canonical representation, $(\tilde{A}, \tilde{B}, \tilde{C})!$ (**2 point**)

- d) With $\alpha = 1$ and the reachable state space form find $u(k) = -\tilde{K}\tilde{x}(k) + k_r r(k)$ such that the closed-loop poles are allocated to -0.5 (both). Find k_r such that $r_\infty = y_\infty$! (**2 point**)

4. Consider the following time discrete problem

$$\begin{aligned} \begin{bmatrix} x_1(k+1) \\ x_2(k+1) \end{bmatrix} &= \begin{bmatrix} 0 & 0 \\ 1 & 0 \end{bmatrix} \begin{bmatrix} x_1(k) \\ x_2(k) \end{bmatrix} + \begin{bmatrix} 1 & 0 \\ 0 & 1 \end{bmatrix} \begin{bmatrix} u_1(k) \\ u_2(k) \end{bmatrix} \\ y(k) &= [1 \quad 1] \begin{bmatrix} x_1(k) \\ x_2(k) \end{bmatrix} + [0 \quad 1] \begin{bmatrix} u_1(k) \\ u_2(k) \end{bmatrix} \end{aligned}$$

- a) Find cost function J provided that the solution of the discrete time Control Algebraic Ricatti Equation is known as $\bar{P} = \begin{bmatrix} 2 & 1 \\ 1 & 2 \end{bmatrix}$, and $Q_u = \begin{bmatrix} 2 & 0 \\ 0 & 2 \end{bmatrix}$ (**1 points**).
- b) Find the closed-loop poles (**1 point**).
- c) Now the system is exposed to process $v(t)$ and sensor noise $w(t)$. The noise is added to input as $u_1(k) + v(k)$ and to output as $y(k) + w(t)$, where the zero mean uncorrelated noise covariances are $R_v = R_w = 1$. Find the (delayed) Kalman filter gain \bar{L} and the observer's poles (**2 point**).
- d) With \bar{K} and \bar{L} draw the LQG controlled system's block diagram, including integrators, gains and signal steams. (**1 point**).

5. Given the following state-space representation and cost functional by,

$$\begin{aligned} \dot{x}(t) &= x(t) + 2u(t) + \sqrt{3}d(t) \\ y(t) &= cx(t) \\ J(u, d) &= \frac{1}{2} \int_0^\infty (y^2(\tau) + u^2(\tau)q_u - \gamma^2 d^2(\tau)) d\tau \end{aligned}$$

where $\gamma = 1$, $q_u = \gamma$. Find the best case control input and worst case disturbance feedback gains that results in $J(u^*, d^*) = \min_u \max_d J(u, d)$ (**1 point**).